

Operation Manual

PP-9214 Pre Amplifier

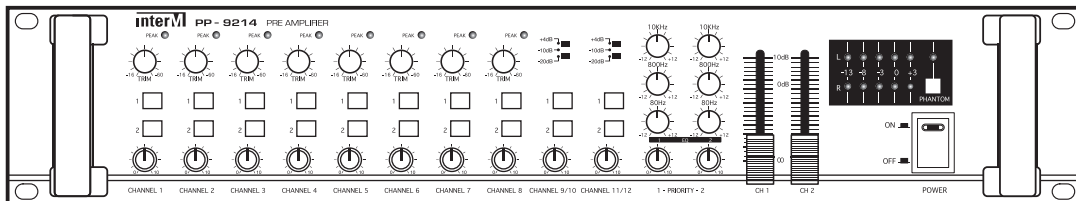

* Rack mount products in the Western Hemisphere(North America, South America, and the Caribbean) do not have handles installed due to

interM

Contents

Welcome	
Warning	1
Unpacking	2
Installation	
Environment	2
Important Safety Instructions	2
Features	3
Accessories	3
Operation	3
Front Panel	4
Rear Panel	6
Applications	8
Block Diagram	9
Specifications	10
Service	
Procedures	11
Schematic	11
Parts List	11
Variations and Options	11
Warranty	11

Welcome

A personal welcome to you from the management and employees of Inter-M

All of the co-workers here at Inter-M are dedicated to providing excellent products with inherently good value, and we are delighted you have purchased one of our products.

We sincerely trust this product will provide years of satisfactory service, but if anything is not to your complete satisfaction, we will endeavor to make things right.

Welcome to Inter-M, and thank you for becoming part of our worldwide extended family!

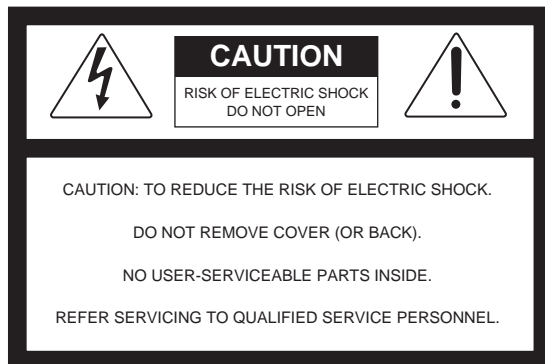

This symbol is intended to alert the user to the presence of uninsulated "dangerous voltage" within the product's enclosure that may be of sufficient magnitude to constitute a risk of electric shock to persons.



This symbol is intended to alert the user to the presence of important operation and maintenance (servicing) instructions in the literature accompanying the appliance.

Caution: To prevent electric shock do not use this (polarized) plug with an extension cord, receptacle or other outlet unless the blades can be fully inserted to prevent blade exposure.

Attentions: Pour prévenir les chocs électriques ne pas utiliser cette fiche polarisée avec un prolongateur, une prise de courant ou une autre sortie de courant, sauf si les lames peuvent être insérées à fond sans en laisser aucune partie à découvert.

WARNING

To prevent fire or shock hazard, do not expose the unit to rain or moisture.

*Do not install this equipment in a confined space such as a book case or similar unit.

*The apparatus shall not be exposed to dripping or splashing and no objects filled with liquids, such as vases, shall be placed on the apparatus.

*Worded: "WARNING FOR YOUR PROTECTION PLEASE READ THE FOLLOWING-WATER AND MOISTURE: Unit should not be used near water(e.g. near a bathtub, washbowl, kitchen sink, laundry tub, in a wet basement, or near a swimming pool, etc). Care should be taken so than objects do not fall and liquids are not spilled into the enclosure through openings."

Unpacking

Although your PP-9214 is neither complicated nor difficult to operate, we recommend you take a few minutes to read this brief manual and familiarize yourself with the important information regarding product features, setup and operation.

As with most electronic devices, we strongly recommend you retain the original packaging. In the unlikely event the product must be returned for servicing, the original packaging (or reasonable equivalent) is required.

Installation

Environment

Never place this product in an environment which could alter its performance or reduce its service life. Such environments usually include high levels of heat, dust, moisture, and vibration.

Important Safety Instructions

1. Read these instructions.
2. Keep these instructions.
3. Heed all warnings.
4. Follow all instructions.
5. Do not use this apparatus near water.
6. Clean only with dry cloth.
7. Do not block any ventilation openings. Install in accordance with the manufacturer's instructions.
8. Do not install near any heat sources such as radiators, heat registers, stoves, or other apparatus (including amplifiers) that produce heat.
9. Do not defeat the safety purpose of the polarized or grounding-type plug. A polarized plug has two blades with one wider than the other. A grounding type plug has two blades and a third grounding prong. The wide blade or the third prong are provided for your safety. If the provided plug does not fit into your outlet, consult an electrician for replacement of the obsolete outlet.
10. Protect the power cord from being walked on or pinched particularly at plugs, convenience receptacles, and the point where they exit from the apparatus.
11. Only use attachments/accessories specified by the manufacturer.
12. Use only with the cart, stand, tripod, bracket, or table specified by the manufacturer, or sold with the apparatus. When a cart is used, use caution when moving the cart/apparatus combination to avoid injury from tip-over.
13. Unplug this apparatus during lightning storms or when unused for long periods of time.
14. Refer all servicing to qualified service personnel. Servicing is required when the apparatus has been damaged in any way, such as power-supply cord or plug is damaged, liquid has been spilled or objects have fallen into the apparatus, the apparatus has been exposed to rain or moisture, does not operate normally, or has been dropped.



Features

- **VERSATILE AND COMPACT**
Flexible mix architecture in a space-saving two RU package.
- **TWELVE INPUTS AND TWO OUTPUTS**
Eight mono inputs and two stereo inputs, plus a stereo output.
- **INPUT AND OUTPUT METERING**
Peak meters on input channels, plus multi-segment LED metering to monitor your output signal.
- **THREE-BAND EQ**
Three-Band EQ control on output section
- **ON-BOARD PHANTOM POWER**
Built-in +18VDC phantom power for condenser microphones
- **AC OR DC OPERATION**
Runs on 100-120VAC, 220-240VAC, or 24VDC for true portability.

Accessories

One detachable AC power cord is provided for use with this product.

Operation

Make certain that speakers and input sources are properly connected before switching on.

Keep volume levels turned down before switching on.

NOTE: The system's operation is delayed by approximately three seconds after pressing the power switch. This is due to the built-in protection circuitry, designed to protect speakers and other system components.

Front Panel

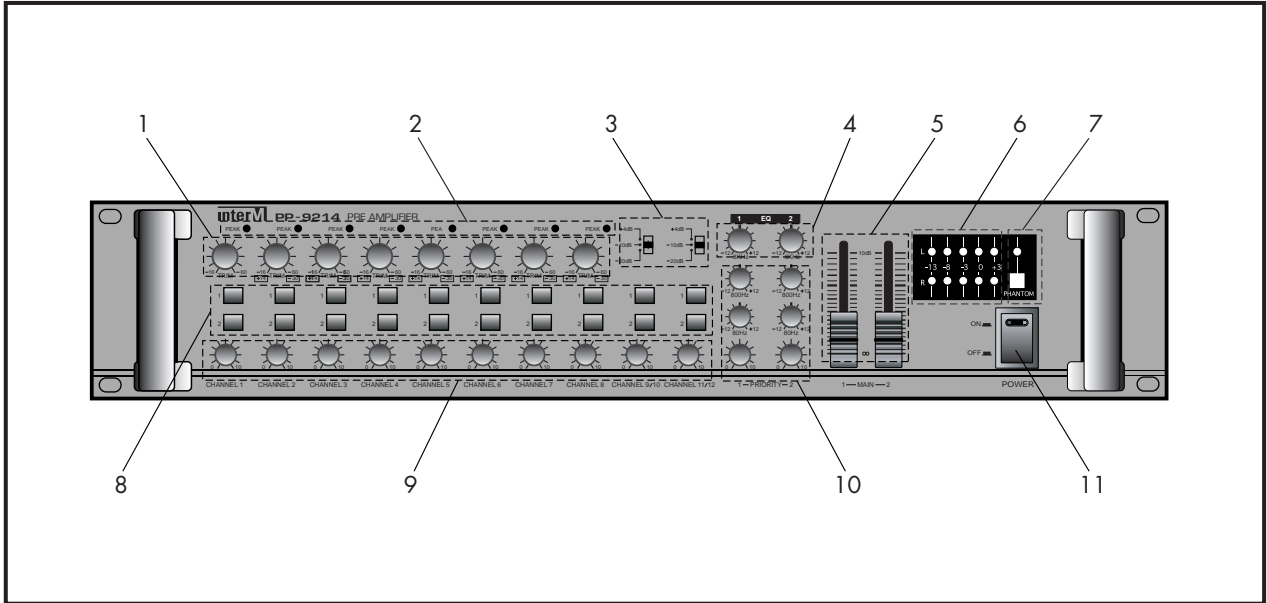

1. TRIM CONTROLS 1-8

These knobs provide continuous control of the gain level for the associated input channel.

2. PEAK INDICATORS 1-8

These LED indicators light when the input signal to the associated channel is 3dB below clipping. If the indicator is lit steadily, reduce the channel's Trim level (1) to avoid distortion.

3. GAIN SELECT SWITCHES 9/10 – 11/12

These switches select the input gain level for Stereo Channels 9/10 and 11/12. You may select between +4dB, -10dB or -20dB input level, depending on your input source. If the signal is too weak (very low level), select a higher setting; if the signal is too hot (overloaded and distorted), select a lower setting.

4. EQ CONTROLS

These knobs provide continuous control of equalization for the stereo (master) output. Three bands of equalization are provided:

Low: 80Hz, ± 12 dB, Shelving

Mid: 800Hz ± 12 dB, Shelving

High: 8kHz ± 12 dB, Shelving

5. MAIN OUTPUT LEVEL CONTROLS

These sliders provide control of the stereo (master) output level. The output level may be monitored by the Output Level Meters (6).

6. OUTPUT LEVEL METERS

These five-segment LED meters monitor the level of the stereo (master) output signal.

7. PHANTOM POWER SWITCH AND INDICATOR

Pressing this switch activates the +18VDC phantom power supply to the Mic Inputs 1-8, for use with condenser mics requiring external power. When Phantom Power is active, the LED indicator lights. Push this switch again to turn off Phantom Power.

8. CHANNEL SELECTOR SWITCHES 1-8

These buttons assign the channel's input signal to one or both of the stereo outputs.

9. CHANNEL OUTPUT LEVELS 1-8

These knobs provide continuous control of the associated channel's output level.

10. PRIORITY LEVEL CONTROL

This knob provides continuous control of the volume of the input signal of the chime, siren, or other audio source connected to the Priority Input jacks on the rear panel. When signal is present at the Priority Input jacks, all other signals except Channel 1 are muted.

11. POWER SWITCH

Pressing this switch turns the unit on, as indicated by the Power LED in the switch. Pressing it again turns the unit off.

Rear Panel

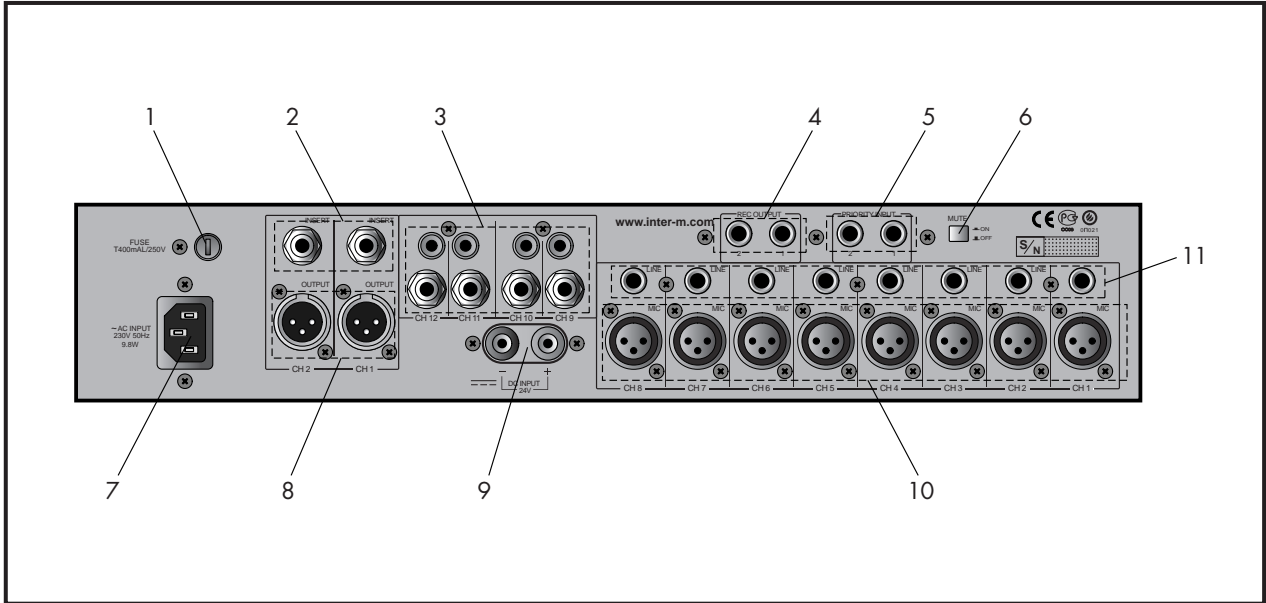

1. AC FUSE HOLDER

This holder contains the AC overload protection fuse. If the fuse has blown out, replace it with a fuse of the same type and rating. If the fuse continues to blow, refer servicing to a qualified service technician.

2. INSERTS

These unbalanced 1/4" TRS jacks are provided for input of an audio source before the master fader. The input signal is unaffected by the Channel Input levels.

3. LINE INPUTS 9-12

Line-level inputs on unbalanced RCA and 1/4" phone connectors. These are provided as two sets of stereo inputs (9/10 and 11/12).

4. REC OUTPUT

These two unbalanced 1/4" line-level inputs are provided for connecting to an external recording device.

5. PRIORITY INPUT

These two unbalanced 1/4" line-level inputs are provided for priority connection of chime/siren equipment. When input signal is present on these inputs, all other audio inputs except Channel 1 are automatically muted.

6. MUTE SWITCH

When this switch is pressed, priority muting is activated, and all signals except Channel 1 and Priority Input are muted.

7. AC POWER INPUT

Connect the supplied standard AC input cable here.

8. MAIN OUTPUTS

These are balanced XLR output jacks for connecting to the input of a power amp.

9. DC INPUT TERMINALS

These terminals are provided for the connection of backup battery. Connect a 24VDC battery source to these terminals. Make certain the red terminal is connected to the battery's positive (+) side, and the black terminal to the battery's negative (-) side.

10. MIC INPUTS 1-8

Mic-level inputs on balanced three-pin XLR connectors.

11. LINE INPUTS 2-8

Line-level inputs on balanced 1/4" phone connectors.

Applications

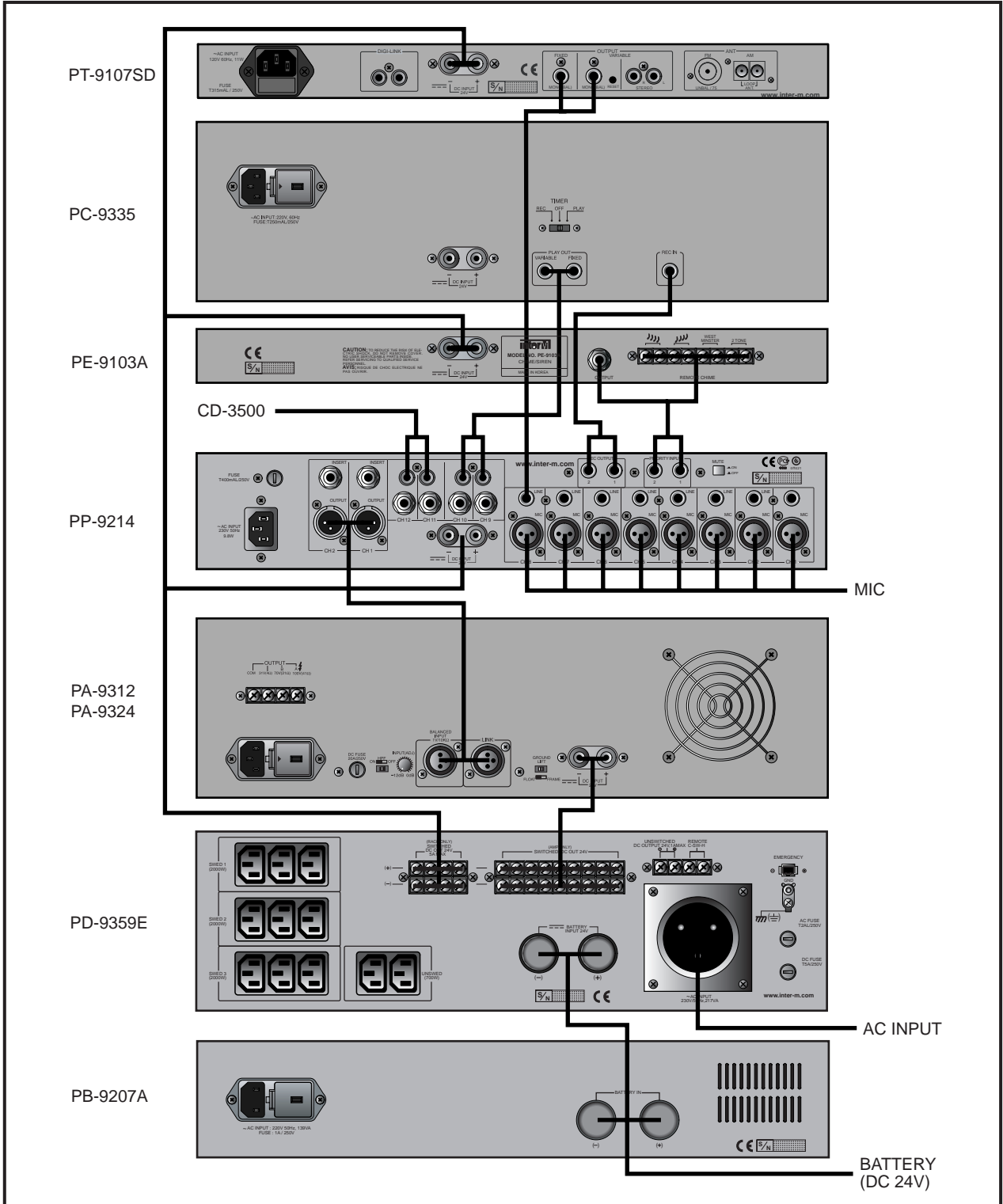

Block Diagram

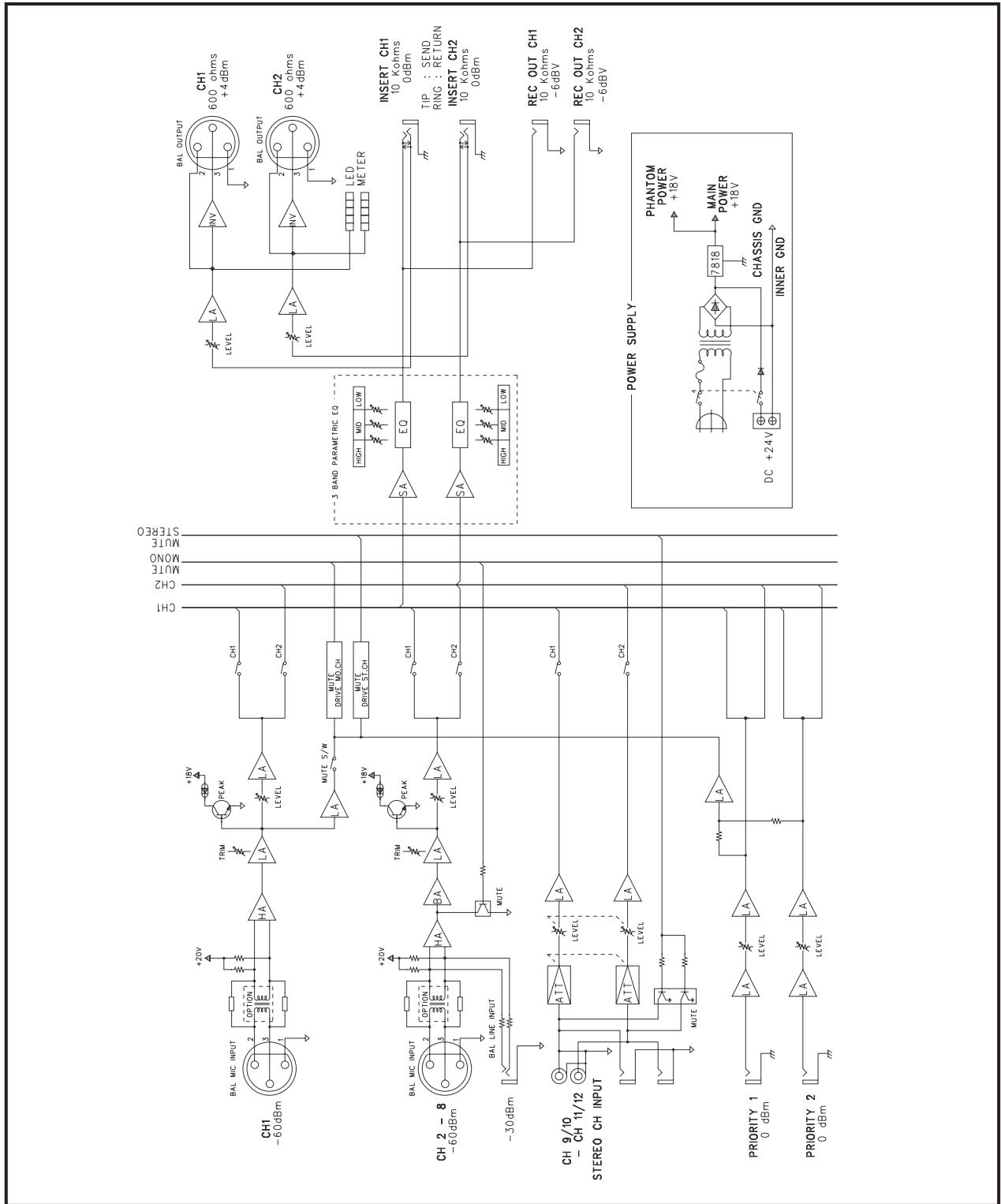

Specifications

- ELECTRICAL

Frequency Response (+1/-3dB)	20Hz-20kHz
T.H.D.....	Less than 0.5%
Input Sensitivity/Impedance	
Mic Input 1-8	-60dB/600Ω Balanced
Line Input 2-8	-30dB/10kΩ Balanced
Line Inputs 9-12	+4dB, -10dB, -20dB/10kΩ Unbalanced
Output/Impedance	
Ch 1-2 (Master).....	+4dB/600Ω Balanced
Rec Out.....	-10dB/10kΩ Unbalanced
Insert	0dB/10kΩ Unbalanced
Residual Noise	
All Faders Min	90dB
All Faders Min, Master Fader Max	70dB
Crosstalk	
Input to Output	70dB
Adjacent	70dB

- GENERAL

Power Source	100-120VAC or 220-240VAC; 50/60Hz, 24VDC Auto-Switching (Supplied AC mains transformer depends on country requirements)
Power Consumption	9.8W
Weight	12.8kg/34.3lb
Dimensions.....	482(W) x 88(H) x 280(D)mm/19(W) x 3.5(H) x 11(D)in

* Specifications and design subject to change without notice.

Service

Procedures

Ensure the problem is not related to operator error, or system devices that are external to this unit. Information provided in the troubleshooting portion of this manual may help with this process. Once it is certain that the problem is related to the product contact your warranty provider as described in the warranty section of this manual.

Schematic

A Schematic is available by contacting your warranty provider.

Parts List

A Parts List is available by contacting your warranty provider.

Variations and Options

Variations

Products supplied through legitimate sources are compatible with local AC power requirements.

Options

No optional items are available for this product.

Warranty

Warranty terms and conditions vary by country and may not be the same for all products. Terms and conditions of warranty for a given product may be determined first by locating the appropriate country which the product was purchased in, then by locating the product type.

To obtain specific warranty information and available service locations contact Inter-M directly(in Korea or the USA) or the authorized Inter-M Distributor for your specific country or region.



Inter-M, Ltd. (Korea) began operations in 1983.

Since then, Inter-M has grown to become one of the largest manufacturers of professional audio and commercial sound electronics equipment in the world.

Inter-M has gained worldwide recognition for its own branded products, as well as private label manufacturing of electronics sold under other names (OEM).

The company is no longer just a Korean company, but rather a global company that is truly international in scope, with factories and offices in Korea and China, and sales and marketing operations located in Japan, Europe, and the U.S.A.

With more than 850 employees around the globe, Inter-M is well-poised for further growth and expansion.

Inter-M Americas, INC.

13875 ARTESIA BLVD. CERRITOS, CA 90703 USA
TEL : +1-562-921-0313, FAX : +1-562-921-0370
Home Page : <http://www.inter-m.net>, E-mail : info@inter-m.net

Inter-M Corporation

SEOUL OFFICE: 653-5 BANGHAK-DONG, DOBONG-KU, SEOUL, KOREA
TEL : +82-2-2289-8140~8, FAX : +82-2-2289-8149
Home Page : <http://www.inter-m.com>, E-mail : overseas@inter-m.com