



Shure Brothers Incorporated  
222 Hartrey Avenue  
Evanston IL 60202-3696 U.S.A.

Phone: 800-257-4873 Fax: 847-866-2279  
In Europe, Phone: 49-7131-72140 Fax: 49-7131-721414  
Internationally, Phone: 847-866-2200 Fax: 847-866-2585  
Web Address: <http://www.shure.com>

## SHURE UHF WIRELESS SYSTEM

## Specification Sheet

### UHF WIRELESS SYSTEM

The Shure UHF Wireless microphone system is a frequency-agile diversity system operating in the UHF band between 782 and 810 MHz (782 to 806 MHz in the U.S.A.). Up to 20 UHF Wireless systems can be operated simultaneously in a single installation.

### FEATURES

- **Frequency Agility.** All Shure UHF transmitters and receivers can be programmed for any frequency within the 782 to 810 MHz band, on 125 kHz centers, for a maximum of 224 frequencies (191 in the U.S.A.)
- **Menu Driven Receiver Display.** User-programmable receiver display shows GROUP, CHANNEL, FREQUENCY, NAME, SQUELCH LEVEL, and receiver function LOCKED/UNLOCKED status.
- **Exclusive Shure MARCAD® Circuitry.** MARCAD (MAXimum Ratio Combining Audio Diversity) circuitry constantly monitors signals from both receiver sections and combines them into a single output signal that is virtually free of noise and dropouts.
- **Dual RF Level Meters.** Monitor RF signal strength at each antenna, and make it easier to identify "dead spots" as well as other RF sources.
- **Audio Level Meters.** Each receiver channel includes a seven-segment audio meter that lets you monitor audio level and helps optimize transmitter gain setting.
- **Transmitter Battery Power Meters.** Monitor transmitter battery power level from the transmitter and receiver.
- **Tone Key Squelch.** Provides audio output only when tone key signal is present in transmitted signal. This eliminates noise associated with loss of carrier.
- **Group/Channel Configuration.** Ensures frequency compatibility and simplifies system installation. Can also be configured by frequency.
- **Network Expansion Capability.** A 25-pin serial connector on the receivers allows future computer control and monitoring.
- **Transmitter DC to DC Converter.** As battery voltage declines, system voltage remains constant for worry-free operation.
- **Switching 90/230 VAC Internal Power Supply in Receivers.** Eliminates the need for a separate external power supply.
- **Independent Headphone Monitor.** Lets user adjust monitor volume without changing receiver output levels.
- **Transmitter Power On/Frequency Change inhibit Function.** Prevent accidental power interruptions, and changes to transmitter frequency settings.
- **Optional U1H High Powered Transmitter .** 100 mW or 50 mW versions of the U1 transmitter are available.
- **Optional UA830A Active Remote Antenna Kit (Figure 7).** Allows remote placement of receiver antennas. Amplifies signal by 3 to 10 dB (user adjustable) to offset cable loss.
- **Optional UA840A Antenna Distribution System (Figure 4).** Provides connection to up to five receivers, using only two antennas.

### SYSTEM COMPONENTS

**U1 Body-Pack Transmitter (Figure 1A)** with detachable lavalier microphone, headset, or instrument cable,

or

**U2 Hand-Held Microphone-Transmitter (Figure 1B)** with interchangeable microphone heads,

and a

**U4S Single Channel MARCAD Diversity Receiver (Figure 2)** with switching power supply (90/230 VAC), AC power cord, front mount antenna hardware, antennas, and rack-mounting hardware,

or a

**U4D Dual Channel MARCAD Diversity Receiver (Figure 3)** with switching power supply (90/230 VAC), AC power cord, front mounting antenna hardware, antennas, and rack-mounting hardware.

### ARCHITECTS' & ENGINEERS' SPECIFICATIONS

The wireless microphone system shall be a frequency-agile, signal combining diversity system which operates in the UHF band between 782.125 MHz and 809.875 MHz (up to 805.875 MHz in the U.S.A.). Hand-held transmitters shall include an integral dynamic or condenser microphone. Body-pack systems shall include either a lavalier microphone, a headset microphone, or an instrument cable, depending on the application.

All transmitters shall be digitally synthesized (phase locked loop) and operate on two (2) AA batteries and shall have a power on/off switch, an adjustable audio gain control, a digital microprocessor controlled LCD display and 5 segment digital battery fuel gauge. They shall also feature both power on/off "lock" as well as frequency-change inhibit options, set via push-buttons within the battery compartment.

All receivers shall be digitally synthesized and shall be compatible with the standard 19" full rack space format. They shall utilize a digital microprocessor to adjust such parameters as NAME, GROUP/CHANNEL, FREQUENCY, SQUELCH, and LOCK. All receivers shall utilize audio combining diversity circuitry which achieves the best possible signal-to-noise ratio. There shall be two type of receivers available: single channel diversity receivers and dual channel diversity receivers. The receivers shall have front panel LEDs that indicate RF signal strength, audio level, and diversity operation. A microprocessor-controlled front panel LCD window display and controls, as well as headphone monitor and volume controls shall also be provided. Front panel BNC connectors on the receiver shall be provided for front-mounting antennas, and a 25-pin serial connector shall be provided on the rear panel to allow future computer control.

The Shure UHF Wireless microphone system is specified.

**OVERALL SYSTEM****RF Carrier Frequency Range**

782.125 to 809.875 MHz (782.125 to 805.875 MHz in the U.S.A.)

**Effective Operating Range**

152.5 m (500 ft.) under typical conditions, 1600 ft. line of sight

**Frequency Response**50 to 15,000 Hz,  $\pm 2$  dB**Total Harmonic Distortion**

0.3% typical at 45 kHz deviation, 1 kHz modulation

**Operating Temperature Range** $-20^{\circ}$  to  $50^{\circ}$  C ( $-4^{\circ}$  to  $122^{\circ}$  F)**Dynamic Range**

&gt;102 dB, A-weighted

**System Polarity**

Positive voltage at transmitter input produces positive voltage at receiver audio outputs (tip or pin 2 relative to pin 3)

**U1/U1L BODY-PACK TRANSMITTER****Output Power**

U1: 10 mW

U1H: 100 mW (U.S.A. version) or 50 mW (European version)

**Audio Gain Adjustment Range**

0–40 dB

**Input Impedance**Tini Q.G. Connector: 18 k $\Omega$ , pin 4 wired to pin 3 for WL93 or other condenser microphone; 1 M $\Omega$  pin 4 open for dynamic microphone or instrument pickup. **NOTE:** Input impedance data for LEMO connector units available upon request.**Maximum Input Level**6 V<sub>p-p</sub> (+7 dBV) for 1% THD, minimum gain setting, 1 kHz signal**Modulation**FM  $\pm 45$  kHz deviation**Antenna**1/4 wave, whip antenna, 50 $\Omega$ **Power Requirements**

Two AA 1.5V alkaline batteries (Duracell MN1500)

**Battery Life**

U1: 12 hours typical (with Duracell MN1500 AA alkaline)

U1H: 6 hours typical (with Duracell MN1500 AA alkaline)

**Dimensions**92.2 mm L x 64.7 mm W x 24.2 mm D (3 <sup>29</sup>/<sub>32</sub> in. H x 2 <sup>35</sup>/<sub>64</sub> in. W x <sup>61</sup>/<sub>64</sub> in. D)**Weight**

175.2 g (6.18 oz.) without battery

**Certification**

Type Accepted under FCC Parts 74; Certified by IC in Canada under TRC-78

**U2 HAND-HELD TRANSMITTER****Output Power**

10 mW

**Audio Gain Adjustment Range**

0 to 26 dB

**Modulation**FM  $\pm 45$  kHz deviation**Maximum Input Level**6 V<sub>p-p</sub> (+7 dBV) for 1% THD, minimum gain setting, 1 kHz signal**Antenna**1/4 wave, helical, 50 $\Omega$ **Power Requirements**

Two 1.5V AA alkaline batteries (Duracell MN1500)

**Battery Life**

12 hours typical (with Duracell MN1500 AA alkaline)

**Dimensions**

U2/58: 254 mm L x 50.8 mm Dia. (10 in. L x 2 in. Dia.)

U2/BETA 58: 254 mm L x 53.2 mm Dia. (10 in. L x 2 <sup>3</sup>/<sub>32</sub> in. Dia.)U2/87: 228.6 mm x 49.2 mm Dia. (9 in. L x 1 <sup>15</sup>/<sub>16</sub> in. Dia.)

U2/BETA 87: 216 mm L x 50.8 mm Dia. (9 in. L x 2 in. Dia.)

**Weight**

U2/58, U2/BETA 58: 375.6 g (13.25 oz.) without battery

U2/87, U2/BETA 87: 303.1 g (10.69 oz.) without battery

**Certification**

Type Accepted under FCC Parts 74; Certified by IC in Canada under TRC-78

**U4S/D MARCAD® DIVERSITY RECEIVER****RF Sensitivity**0.45  $\mu$ V for 12 dB SINAD (typical)**Image Rejection**

&gt;90 dB

**Spurious Rejection**

&gt;75 dB typical

**Ultimate Quieting** (ref.  $\pm 45$  kHz deviation)

&gt;100 dB, A-weighted

**Squelch Quieting** (ref.  $\pm 45$  kHz deviation)

&gt;95 dB, A-weighted

**Antenna Input Impedance**50 $\Omega$  nominal**Antenna**1/2 wave, dipole, 50 $\Omega$ **Output Configuration**1/4 inch connector, balanced, 1 k $\Omega$  impedanceXLR connector, balanced, 30  $\Omega$  impedance**Mic/LineAudio Output** $-22$  dBV (mic) +2 dBV (line)**Power Requirements**

90 to 230 VAC (automatic switching)

**Dimensions**U4S/U4D: 44.5 mm H x 482.6 mm W x 295.3 mm D (1 <sup>3</sup>/<sub>4</sub> H in. x19 in. W x 11 <sup>5</sup>/<sub>8</sub> D in.)**Weight**

U4S: 3.30 kg (7 lb, 4.3 oz.)

U4D: 3.85 kg (8 lb, 0.5 oz.)

**Certification**

Approved under the Notification provision of FCC Part 15; Certified by IC in Canada under TRC-78

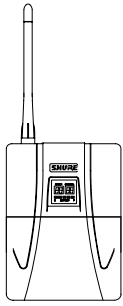

**U1 BODY-PACK TRANSMITTER**

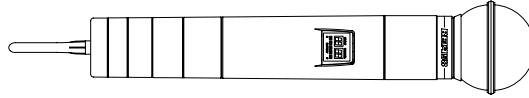

**U2 HAND-HELD MICROPHONE TRANSMITTER**

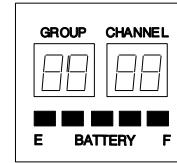

**TRANSMITTER DISPLAY PANEL (DETAIL)**

**FIGURE 1**

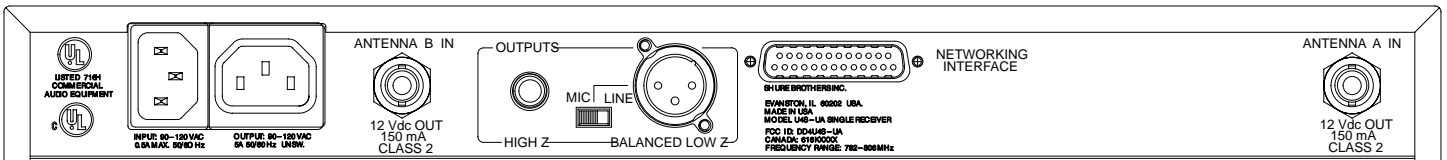
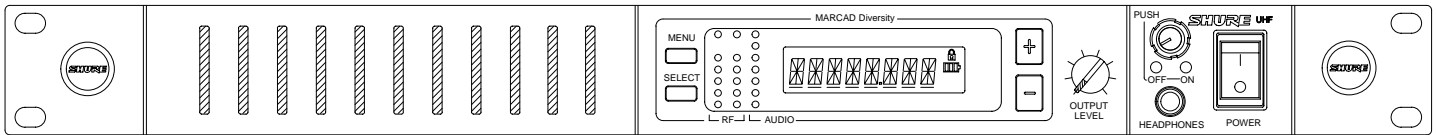

**U4S SINGLE CHANNEL MARCAD DIVERSITY RECEIVER**

**FIGURE 2**

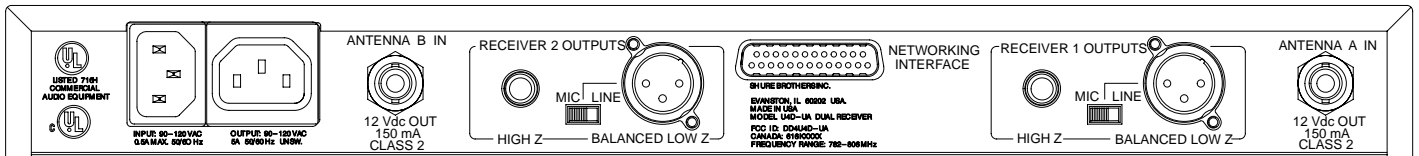
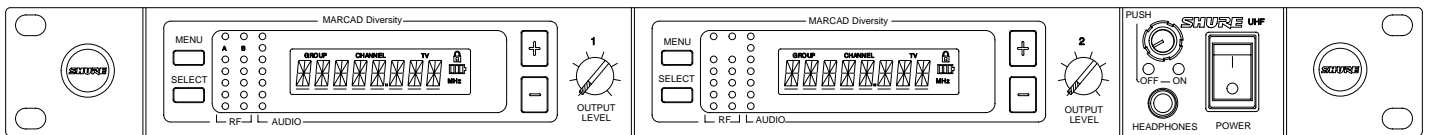

**U4D DUAL CHANNEL MARCAD DIVERSITY RECEIVER**

**FIGURE 3**

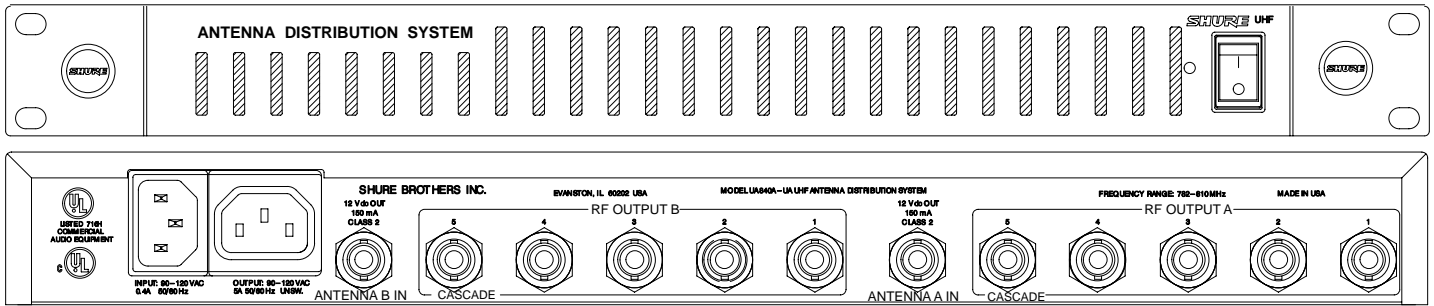

**UA840A ANTENNA DISTRIBUTIONS SYSTEM**  
**FIGURE 4**

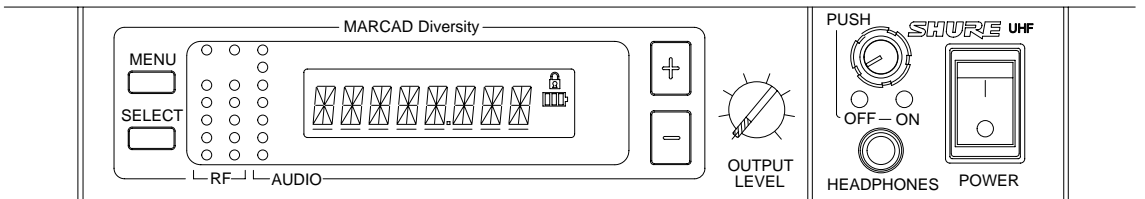

**U4S/U4D CONTROL PANEL (DETAIL)**  
**FIGURE 5**

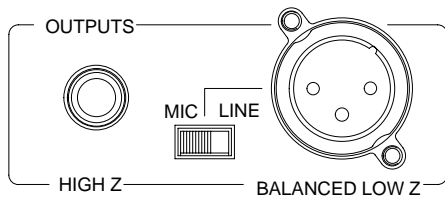

**U4S/U4D SIGNAL OUTPUT (DETAIL)**  
**FIGURE 6**

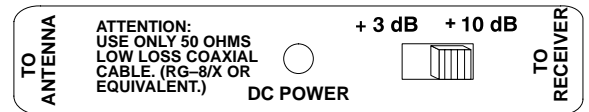

**UA830A FRONT PANEL (DETAIL)**

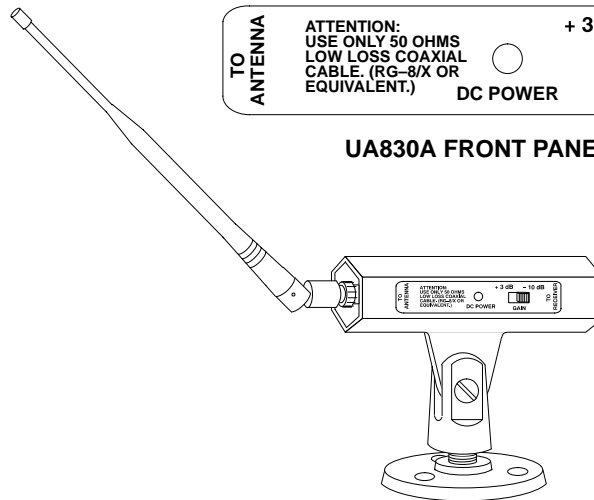

**UA830A ACTIVE REMOTE ANTENNA KIT**  
**FIGURE 7**