



INSTRUCTION MANUAL

SONANCE VIRTUOSO® SERIES

SSDR & VRS2 SPEAKERS

INTRODUCTION

Thank you for purchasing Sonance Virtuoso® SSDR/VRS2-series speakers. When properly installed, these speakers will give you many years of entertainment pleasure. To get the most out of your new speakers, please read this manual thoroughly before you begin installation.

This manual covers the Virtuoso V833SSDR, V831SSDR and VRS2 models:

To achieve the best performance, Sonance recommends that these speakers be installed by a Sonance Authorized Dealer/Installer.

SAFETY WARNING:

These speakers have FastMount® tabs that prevent the speaker from falling out of the mounting hole during the installation process.

The edges of FastMount tabs are very sharp. Use caution when handling the speaker.

See *Installation* (page 4) for complete information about the FastMount tabs.

PARTS LIST

Your Sonance Virtuoso SSDR speaker includes the following:

- (1) Sonance Virtuoso SSDR Speaker
- (1) Paintable Grille
- (1) Plastic paint plug to protect speaker during painting
- (1) Mounting cutout template (in packaging)

Your Sonance Virtuoso VRS2 speakers include the following:

- (2) Sonance Virtuoso VRS2 Speakers
- (2) Paintable Grilles
- (2) Plastic paint plugs to protect speakers during painting
- (1) Mounting cutout template (in packaging)

OPTIONAL ACCESSORIES

Virtuoso_{DR} Metal Grille (part# 92290): Metal replacement for included grilles.

Virtuoso_{DR} Cloth Grille (part# 92285): Cloth-covered replacement for included grilles.

Virtuoso_{DR} FlexBracket (part# 92247): Plastic template to reserve a mounting hole for the speaker in new construction. Designed to be used with the RotoLock® mounting system.

Virtuoso_{DR} Coverplate (part# 92245): Covers the hole made by the FlexBracket during construction until the speaker is installed.

Virtuoso_{DR} Acoustic Enclosure (part# 91900): ½" MDF enclosure that provides ideal acoustic performance and maximum reduction of sound transmission into adjacent spaces. Designed for use only in new construction.

Virtuoso_{DR} Retrofit Enclosure (part# 92243): Molded enclosure that reduces sound transmission into adjacent rooms and spaces. Can be used in both new construction and retrofit installations.

Virtuoso_{DR} Fire-Rated Back Can (part# 91908): Meets ASTM E 119 and UL2043 criteria for commercial installations.

Sonafill® In-Ceiling System (part# 91928): Retrofittable acoustical treatment consisting of two pillows and four tiles that virtually eliminates noises produced by resonating drywall. Dramatically improves midbass sound quality and reduces sound transmission into adjacent rooms.

SPEAKER PLACEMENT

V833SSDR and V831SSDR

Virtuoso Single Stereo Technology® SSDR speakers are ideal for use in hallways, bathrooms, closets, or in any location where listeners will be moving around and a pair of stereo speakers would be impractical.

The location of the speaker should be determined by considering the primary listening location as well as aesthetic values. Because a single Virtuoso SSDR reproduces both stereo channels from a single location, they will deliver outstanding performance from an extremely wide variety of mounting locations.

For optimum results contact your Authorized Sonance Dealer for advice.

Distributed Audio Placement

Sonance Virtuoso speakers have very smooth and predictable off-axis response, increasing placement options while providing excellent coverage in distributed audio systems. The chart below shows how far apart the speakers can be placed while still providing good coverage. The distances are based on ear heights of 62" for standing listeners and 40" for seated listeners.

Speaker spacing in feet for a distributed audio system		
	Standing Listener	Seated Listener
8-foot ceiling	5.7'	9.5'
10-foot ceiling	9.7'	13.5'
12-foot ceiling	13.7'	17.5'
14-foot ceiling	17.7'	21.5'

VRS2: 5.1-Channel Home Theater System (see *Illustration 1*)

Locate the left and right VRS2 surround speakers on the ceiling between 2 feet and 4 feet behind the listening position. The speakers should be between 8 feet and 12 feet apart.

Orient the speakers so the dual midrange/tweeter assemblies face the front and rear walls of the room.

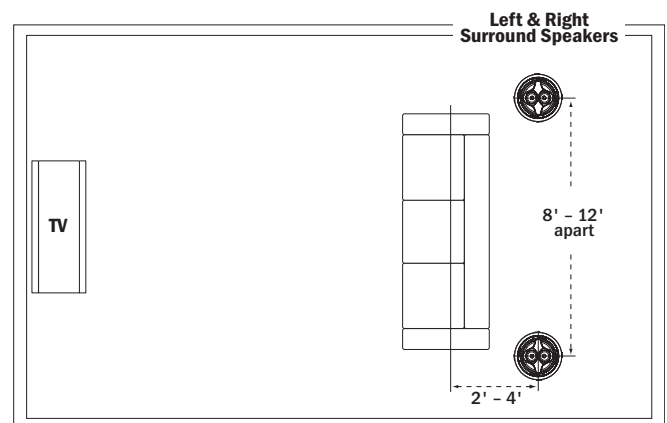

Illustration 1: VRS2 Placement in a 5.1-Channel Home Theater



INSTRUCTION MANUAL

SONANCE VIRTUOSO® SERIES

SSDR & VRS2 SPEAKERS

VRS2: 7.1-Channel Home Theater System (see Illustration 2)

- **Left & Right Surround Speakers:** Place the left and right surround speakers anywhere from directly to the sides of the listening position to 2 – 3 feet in front of it, and between 8 feet and 12 feet apart. Orient the speakers so the dual midrange/tweeter assemblies face the front and rear walls of the room.
- **Surround Back Speakers:** Place the surround back speakers 4 – 8 feet behind the listening position. The surround back speakers should be closer together than the left and right surround speakers: 6 – 10 feet apart. Orient the speakers so the dual midrange/tweeter assemblies face the left & right side walls of the room.

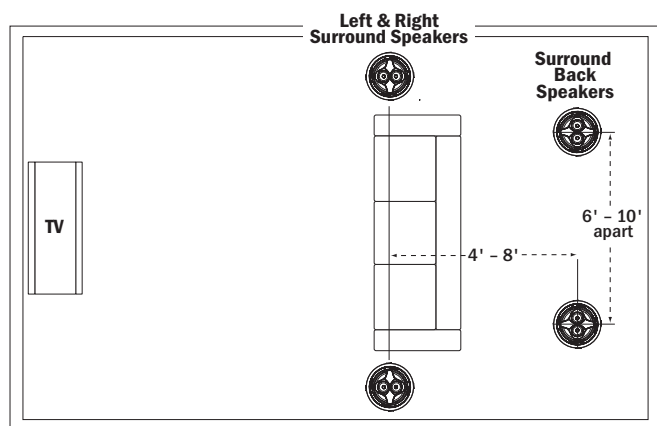

Illustration 2: VRS2 Placement in a 7.1-Channel Home Theater

WIRE GAUGE

Extra resistance in the speaker wire can make speakers sound less dynamic and reduce definition of the bass frequencies. In extreme cases, it can even attenuate high frequencies. Also, amplifier power is wasted in wire with extra resistance, reducing your system's maximum output level.

To prevent degrading sound quality, the total wire resistance should be less than 10% of the speaker's impedance. This means that for an 8-ohm speaker, the total resistance of the wire should be less than 0.8 ohms.

Refer to the following table when selecting the proper wire gauge for your system:

Wire resistance in Ohms vs. length of cable run						
Distance in Feet	50'	100'	150'	200'	250'	300'
20 gauge	1.04	2.07	3.11	4.14	5.18	6.22
18 gauge	.65	1.30	1.96	2.61	3.26	3.91
16 gauge	.41	.82	1.22	1.63	2.04	2.45
14 gauge	.26	.52	.77	1.03	1.29	1.55
12 gauge	.16	.32	.49	.65	.81	.97
10 gauge	.10	.20	.31	.41	.51	.61

PREPARING THE INSTALLATION LOCATION

All Sonance speakers are designed to be relatively insensitive to variations in enclosure volume. To achieve the ultimate performance from your speakers, a section of the ceiling bay can be sectioned-off to form a back box. Building such an enclosure will create a dramatic improvement in your speakers' bass performance and power handling.

Ideal back box volume requirements:

Virtuoso V833SSDR:	2.2 ft ³
Virtuoso V831SSDR	2.0 ft ³
Virtuoso VRS2	2.2 ft ³

Insulating the Ceiling Cavity

You can reduce sound transmission to adjacent rooms and further improve speaker performance by inserting a sheet of unfaced fiberglass insulation over the back of the speaker. To reduce noise produced by unsupported drywall, install fiberglass insulation in the ceiling bays adjacent to the speaker location.

Optional Virtuoso^{DR} Retrofit Enclosures

For installations where it isn't possible to section-off the ceiling bay to form a back box (such as when you're retrofitting the speakers into an existing ceiling), you can effectively reduce sound transmission into adjacent rooms by fitting the speakers with optional Virtuoso Retrofit Enclosures (part# 92243). This enclosure is designed specifically to be used with Virtuoso DR, SSSDR and VRS2 speakers, and will noticeably reduce sound "spillover" from the rears of the speakers into adjacent rooms and spaces.

INSTALLING THE SPEAKERS

For more information about flangeless installation contact your Authorized Sonance Dealer or visit www.sonance.com.

Before Installation: New Construction

For installations in new construction, Sonance recommends using a Virtuoso FlexBracket (part# 92247) to reserve a location for the speaker. The FlexBracket is nailed or screwed to the studs and serves as a guide for the drywall so that the speaker hole will be in the desired location once the drywall is installed.

Virtuoso FlexBrackets are compatible with the RotoLock™ mounting system.

Before Installation: Retrofit

1. Determine the location for the speaker (see *Speaker Placement* on page 1).
2. Perform an obstruction survey to be certain that there are no studs, conduit, pipes, heating ducts or air returns that will interfere with the speaker.
3. The cutout for Virtuoso SSSDR and VRS2 speakers is 10¹/₈" (257mm). There also must be at least 6" (152mm) depth within the ceiling cavity for the speaker.
4. Position the included cutout template where the speaker is to be located and pencil an outline on the ceiling.
 - If you are unsure about obstructions, drill a small hole in the center of the outline and insert a coat hanger wire into the hole to feel-around for possible obstructions.
5. Cut the hole using a drywall saw, and run the speaker wires.

Installation

Sonance Virtuoso SSSDR and VRS2 speakers feature exclusive FastMount™ tabs and an integral RotoLock® mounting system for quick mounting directly into existing ceilings and walls.

WARNING: The edges of FastMount tabs are very sharp. Use caution when handling the speaker.



INSTRUCTION MANUAL

SONANCE VIRTUOSO® SERIES

SSDR & VRS2 SPEAKERS

1. Remove the paint plug from the speaker. Connect the speaker wire to the terminals on the speaker. Double-check that you connected amplifier + to speaker + and amplifier – to speaker –.
 2. Make sure all the RotoLock clamps are in the full clockwise position so that they are tucked within the mounting hole's border. Insert the speaker into the hole in the ceiling. The RotoLock system can accommodate a maximum ceiling material thickness of 1¼".
- The FastMount tabs will prevent the speaker from falling out of the mounting hole, allowing the installer to let go of the speaker to pick-up tools or other items (see *Illustration 4*).

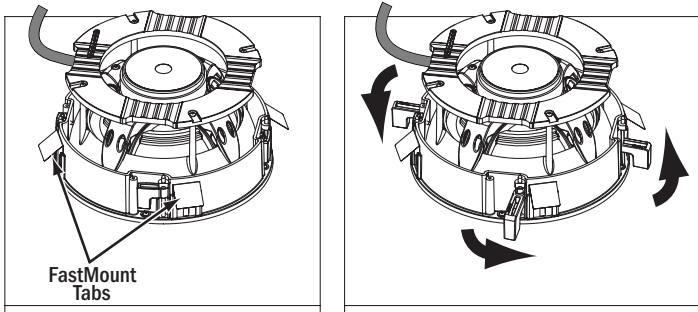

Illustration 4: Virtuoso SSDR/VRS2 Installation

Note: The FastMount tabs are designed for one-time use only. If the speaker is removed from the mounting hole the FastMount tabs will disconnect and remain inside the wall.

3. Tighten the four screws on the front of the speaker baffle. The RotoLock clamps will automatically rotate into position and begin clamping the speaker (see *Illustration 4*).
- When you notice resistance on the screws the speaker has been clamped successfully.

Note: The speaker flange is designed to flex and conform to any small imperfections in the ceiling surface. Do not tighten the screws so much so that the flange bows-out.

Important: Always use low-torque settings; NEVER over-tighten.

4. Attach the grille after the speaker has been installed. Insert about half of the grille into the groove at the edge of the speaker. Gently fit the remaining half of the grille by working around the speaker, fitting the grille into the groove as you go.

Note: You can adjust the torque applied to the RotoLock screws to achieve a proper grille fit.

PAINTING THE SPEAKERS AND GRILLES

You can paint the speakers and grilles before installing them, which will eliminate the “paint scar” if the speaker ever needs to be removed for service. You can also paint the speakers after installation, but before the grilles are attached. Virtuoso SSDR and VRS2 speakers come from the factory fitted with a plastic ‘paint plug.’ Use the paint plug to protect the speaker drivers while the flange is being painted along with the wall.

Sonance always suggests painting the grille separately from the speaker. Before painting, carefully remove the under-grille cloth. It is held in place with a light tacking glue that makes it easy to remove.

Spray the grilles with thinned paint (5 parts thinner to 1 part paint), being careful not to plug the holes. Too heavy a coat of paint on the grille will adversely affect the sound of the speaker.

Once the grilles and flange are painted and dry, replace the under-grille cloth, remove the paint plug from the speaker flange and install the grille.

ADJUSTING THE SPEAKERS

Pivoting Woofer

Virtuoso SSDR and VRS2 speakers have a pivoting woofer assembly. These pivoting drivers allow you to direct sound toward or away from the listening area, depending on the requirements of the installation.

For VRS2 speakers being used as surround channel speakers in a home theater, you can create a more diffuse, spacious surround effect by pivoting the woofers towards a wall or window, away from the listeners.

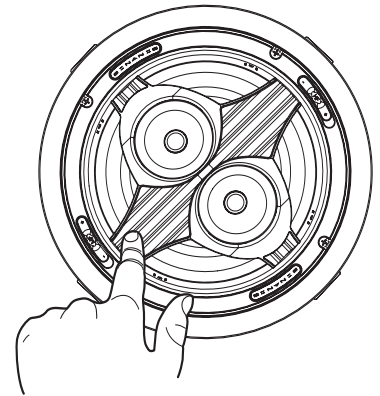

Illustration 5: Pivoting the Woofer

To pivot the woofer:

Apply pressure on the outer edge of the Sonic Eye support bracket, as shown in *Illustration 5*. Do not touch or apply pressure to the woofer cone.

Tweeter & Midrange Level Controls (V833SSDR & VRS2 only)

The V833SSDR and VRS2 have tweeter and midrange level control switches that let you boost or cut the tweeter and midrange levels by 3dB. (See *Illustration 6*.)

Once you have installed the speakers, listen to a variety of music that you are familiar with. If the music *all* tends to sound too bright or dull, use the Tweeter Control to compensate. If the music *all* tends to have too much or too little presence, use the Midrange Control to compensate. If some recordings sound dull or lack presence and some sound bright and have too much presence, the speaker is accurately reproducing differences in the recordings, and you should leave the control in the middle (0dB) position.

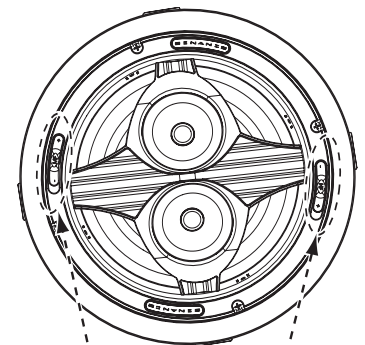

Illustration 6: Tweeter and Midrange Level Controls



INSTRUCTION MANUAL

SONANCE VIRTUOSO® SERIES

SSDR & VRS2 SPEAKERS

SPECIFICATIONS

V833SSDR

Tweeter:	Two ¾" (19mm) Silk domes, Ferrofluid cooled
Midrange:	Two 3" (76mm) Carbon Fiber cones, rubber surrounds
Woofers:	8" (203mm) Carbon Fiber cone, dual voice coil, rubber surround, pivoting
Frequency Response:	32Hz – 20kHz ±3dB
Impedance:	6 Ohms nominal; 4 Ohms minimum
Power Handling:	5 Watts minimum; 150 Watts maximum
SPL:	91dB SPL (2.83V 1 meter)
Grille Material:	Perforated Aluminum
Adjustments:	Tweeter and midrange level (±3dB)
Dimensions (Dia. x D):	11¼" x 6" (286mm x 152mm)
Cutout Diameter:	10⅛" (257mm)
Shipping Weight:	10 lbs. (4.5kg) Each

V831SSDR

Tweeter:	Two ¾" (19mm) Silk domes, Ferrofluid cooled
Midrange:	Two 3" (76mm) Polypropylene cones, rubber surrounds
Woofers:	8" (203mm) Polypropylene cone, dual voice coil, rubber surround, pivoting
Frequency Response:	45Hz – 20kHz ±3dB
Impedance:	8 ohms nominal; 6 ohms minimum
Power Handling:	5 Watts minimum; 100 Watts maximum
Sensitivity:	89dB SPL (2.83V 1 meter)
Grille Material:	Perforated Aluminum
Adjustments:	None
Dimensions (Dia. x D):	11¼" x 6" (286mm x 152mm)
Cutout Diameter:	10⅛" (257mm)
Shipping Weight:	8 lbs. (3.6kg) Each

VRS2

Tweeter:	Two ¾" (19mm) Silk domes, Ferrofluid cooled
Midrange:	Two 3" (76mm) Carbon Fiber cones, rubber surrounds
Woofers:	8" (203mm) Carbon Fiber cone, rubber surround, pivoting
Frequency Response:	32Hz – 20kHz ±3dB
Impedance:	6 Ohms nominal; 4 Ohms minimum
Power Handling:	5 Watts minimum; 150 Watts maximum
SPL:	91dB SPL (2.83V 1 meter)
Grille Material:	Perforated Aluminum
Adjustments:	Tweeter and midrange level (±3dB)
Dimensions (Dia. x D):	11¼" x 6" (286mm x 152mm)
Cutout Diameter:	10⅛" (257mm)
Shipping Weight:	20 lbs. (9.0kg) Pair

TECHNICAL ASSISTANCE AND SERVICE

If you any have questions about the operation or installation of this product, please call our Technical Assistance Department on any business day at (800) 582-0772 or (949) 492-7777; from 7 a.m. to 5 p.m., PST.

If your speakers should need repair or service, contact your Sonance Authorized Dealer for help, or use the following procedure:

1. Prior to calling, note the product's model number, serial number, purchase date, and the name and address of the dealer where you purchased the product.
2. Contact our Technical Assistance Department at the above number(s) and describe the problem the unit is experiencing. If applicable, they will issue a Return Authorization Number.

IMPORTANT: YOU MUST HAVE PRIOR AUTHORIZATION TO RETURN YOUR SPEAKER TO SONANCE!

3. If you're directed to return the unit to Sonance for repair, pack the unit in its original shipping carton. If needed, you can obtain replacement packaging from us for a small charge. Note: it is best if you place the box into an additional outer "overcarton" before shipment to minimize a chance of theft in shipment. Please include a copy of the original bill of sale inside the package.
4. Contact a package delivery service such as United Parcel Service or Federal Express to arrange prepaid (not collect) shipping. Do not use the U.S. Postal Service.

IMPORTANT: Freight collect shipments will be refused.

5. **Write the Return Authorization Number on the outside of the shipping carton.**
6. Ship the packaged unit to:

Quality Assurance Department
 Sonance
 212 Avenida Fabricante
 San Clemente, CA 92672-7531



INSTRUCTION MANUAL

SONANCE VIRTUOSO® SERIES

SSDR & VRS2 SPEAKERS

LIMITED LIFETIME WARRANTY COVERAGE (U.S. ONLY)

Sonance warrants to the original retail purchaser only that this Sonance product will be free from defects in materials and workmanship, provided the speaker was purchased from a Sonance Authorized Dealer.

Defective products must be shipped, together with proof of purchase, prepaid insured to the Authorized Sonance Dealer from whom they were purchased, or to the Sonance factory at the address listed on this instruction manual. Freight collect shipments will be refused. It is preferable to ship this product in the original shipping container to lessen the chance of transit damage. In any case, the risk or loss or damage in transit is to be borne by the purchaser. If upon examination at the factory or Authorized Sonance Dealer it is determined that the unit was defective in materials or workmanship at any time during this warranty period, Sonance or the Authorized Sonance Dealer will, at its option, repair or replace this product at no additional charge, except as set forth below. If this model is no longer available and can not be repaired effectively, Sonance, at its sole option, may replace the unit with a current model of equal or greater value. In some cases where a new model is substituted, a modification to the mounting surface may be required. If mounting surface modification is required, Sonance assumes no responsibility or liability for such modification. All replaced parts and product become the property of Sonance. Products replaced or repaired under this warranty will be returned to the original retail purchaser, within a reasonable time, freight prepaid.

This Warranty does not include service or parts to repair damage caused by accident, disaster, misuse, abuse, negligence, inadequate packing or shipping procedures, commercial use, voltage inputs in excess of the rated maximum of the unit, or service, repair or modification of the product which has not been authorized or approved by Sonance. This Warranty also excludes normal cosmetic deterioration caused by environmental conditions. This Warranty will be void if the Serial Number on the product has been removed, tampered-with or defaced. This Warranty is in lieu of all other expressed warranties. If the product is defective in materials or workmanship as warranted above, the purchaser's sole remedy shall be repair or replacement as provided above. In no event will Sonance be liable for any incidental or consequential damages arising out of the use or inability to use the product, even if Sonance or an Authorized Sonance Dealer has been advised of the possibility of such damages, or for any claim by any other party.

Some states do not allow the exclusion or limitation of consequential damages, so the above limitation and exclusion may not apply. All implied warranties on the product are limited to the duration of this expressed Warranty. Some states do not allow limitation on the length of an implied warranty. If the original retail purchaser resides in such a state, this limitation does not apply.

EXCLUSIONS AND LIMITATIONS

The warranty set forth above is in lieu of all other warranties, express or implied, of merchantability, fitness for a particular purpose, or otherwise. The warranty is limited to Sonance products registered herein and specifically excludes any damage to loudspeakers and other allied or associated equipment which may result for any reason from use with this product. Sonance shall, in no event, be liable for incidental or consequential damages arising from any breach of this warranty or otherwise. This warranty gives you specific legal rights, and you may have other rights which vary from state to state.



©2006 Sonance. All rights reserved.

Sonance, Sonance Virtuoso, Single Stereo Technology, RotoLock, Sonic Eye, Sonafill and FastMount are trademarks or registered trademarks of Dana Innovations. Due to continuous product improvement, all specifications are subject to change without notice. For the latest Sonance product specification information visit our website: www.sonance.com

Sonance • 212 Avenida Fabricante • San Clemente, CA 92672-7531, USA • (800) 582-7777 or (949) 492-7777 • FAX: (949) 361-5151 • Technical Support: (800) 582-0772

www.sonance.com